

interstuhl

Goal-Air

Bedienungsanleitung
Operating instructions
Mode d'emploi
Gebruiksaanwijzing
Instrucciones de uso
Istruzioni d'uso

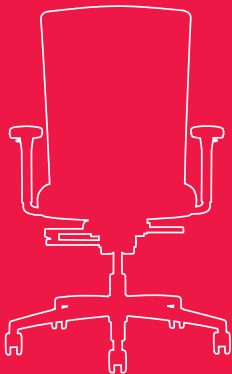

Montage, Rollen und Stuhlsäule

Assembly, castors and chair column

Montage, roulettes et vérin

Montage, wielen en gasveer

Montaje, ruedas y pistón de gas

Montaggio, ruote colonna centrale con pistone a gas



Montage, Rückenlehne

Assembly, backrest

Montage, dossier

Montage, rugleuning

Montaje, respaldo

Montaggio, schienale

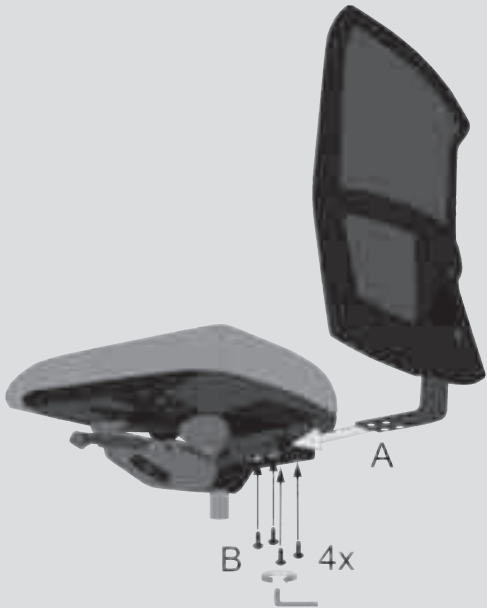



Sitzhöhenverstellung

Seat height adjustment

Réglage de la hauteur d' assise

Zithoogteverstelling

Regulación de altura del asiento

Regolazione altezza seduta





Synchronmechanik

Synchronous mechanism

Mécanisme synchrone

Synchroontehniek

Mecanismo sincronizado

Meccanismo syncro





Gewichtsregulierung

Weight adjustment

Réglage de tension

Gewichtsregeling

Regulación de peso

Regolazione peso

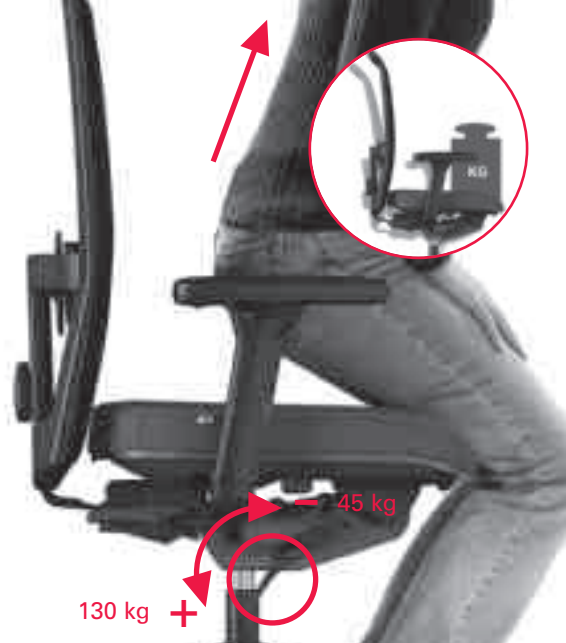

45 kg

130 kg +



Lordosenstütze (Option)

Lumbar support (option)

Soutien lombaire (option)

Lendensteun (optie)

Apoyo lumbar (opción)

Supporto lombare (opzione)





Rückenlehnen-Höhenverstellung

Back height adjustment

Dossier réglable en hauteur

Rugleuning in hoogte verstelbaar

Regulación de altura del respaldo

Regolazione altezza schienale

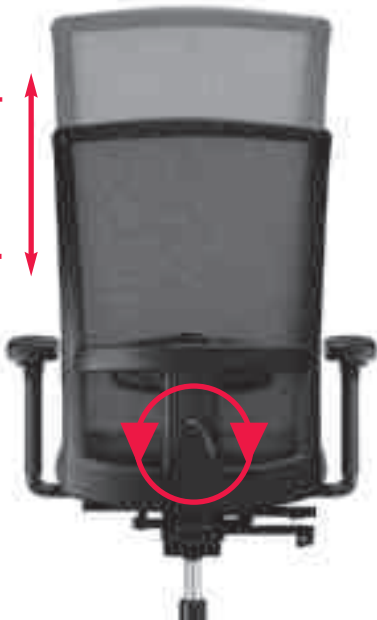



Sitztiefenverstellung (Option)

Seat depth adjustment (option)

Réglage la profondeur d' assise (option)

Zitdiepteverstelling (optie)

Regulación de la profundidad del asiento (opción)

Regolazione profondità seduta (opzione)



2.
- +

1.



Sitzneigeverstellung (Option)

Seat inclination adjustment (option)

Réglage de l'inclinaison d' assise (option)

Zitneigverstelling (optie)

Regulación de la inclinación del asiento (opción)

Regolazione inclinazione seduta (opzione)





Höhenverstellung der Armlehnen

Height adjustable armrests

Accoudoirs réglables en hauteur

Hoogteverstelling van de armleggers

Regulación de la altura de los brazos

Regolazione altezza braccioli





Breitenverstellung der Armlehnen

Width adjustable armrests

Accoudoirs réglables en largeur

Breedteverstelling van de armleggers

Regulación del ancho de los brazos

Regolazione larghezza braccioli





Tiefenverstellung der Armauflage

Adjustable arm supports

Avant - bras réglable

Armleggeropdek in diepte verstelbaar

Superficie de apoyo de los brazos regulable en profundidad

Regolazione parte superiore braccioli





Armauflage schwenkbar

Swivel arm support

Avant - bras pivotants

Armleggeropdek zwenkbaar

Brazos retrotraibles

Parte superiore del bracciolo girevole

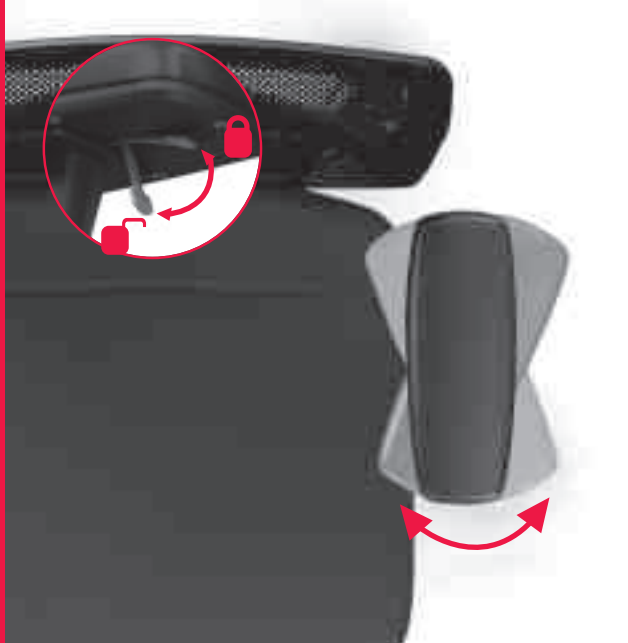



175G

165G

Kopfstütze - Höhenverstellung

Headrest - height adjustment

Repose-tête - réglable en hauteur

Hoofdsteun - hoogteverstelling

Reposacabezas - regulación de altura

Poggiatesta - regolazione altezza





175G

165G

Kopfstütze - Tiefenverstellung

Headrest - depth adjustment

Repose-tête - réglage de la profondeur

Hoofdsteun - diepteverstelling

Reposacabezas - regulación de la profundidad

Poggiatesta - regolazione profondità



www.interstuhl.de

Interaktive Bedienungsanleitung
Interactive operating instructions
Mode d'emploi interactif
Interactieve gebruiksaanwijzing
Instrucciones de uso interactivo
Istruzioni d'uso interattive

Reinigungs- und Pflegehinweise
Care and maintenance
Conseils d'entretien et de nettoyage
Reinigings- en schoomaakinstructies
Indicaciones de Limpieza
Uso e manutenzione



Qualitätszertifikate
Quality certificates
Certificats de qualité
Kwaliteitscertificaten
Certificados de calidad
Certificati di Qualità

Der Hersteller haftet nicht für Schäden aus unsachgemäßem Gebrauch oder aus Nachlässigkeiten in der Wartung. Im Rahmen des GS-Zeichens werden Bürostühle mit einer Belastung, die 120 kg Körpergewicht entspricht, geprüft.

The manufacturer is not liable for damages due to improper use or negligence of maintenance. The GS-Certificate proves that office chairs are able to carry the body weight of 120 kilo gram.

Le fabricant n'est pas responsable de dommages résultant d'une utilisation non conforme du produit et de dommages résultant d'opérations de maintenance. Dans le cadre du Certificat GS, les sièges de bureau correspondent à une charge de 120 Kg.

De fabrikant is niet aansprakelijk voor schade die ontstaan door oneigenlijk gebruik of nalatigheid in het onderhoud. Conform het GS-certificaat (gecontroleerde veiligheid) worden kantoor-draaistoelen getest met een belasting die overeenkomt met 120 kg lichaamsgewicht.

El fabricante no se responsabiliza de posibles daños causados a raíz de un uso indebido del producto o de negligencias en el mantenimiento. El certificado GS demuestra que las sillas de oficina son capaces de aguantar un peso corporal de 120 Kg.

Il produttore non è responsabile per danni dovuti ad un uso improprio o a negligenza nella manutenzione della merce. Il certificato GS prova che le sedie per ufficio hanno una portata massima di peso corporeo pari a 120 Kg.

172G



175G



Goal-Air Bürodrehstühle

Goal-Air swivel chairs

Goal-Air sièges de bureau pivotants

Goal-Air draaistoelen

Goal-Air sillas giratorias

Goal-Air sedia girevole

162G



165G



570G



575G



Goal-Air Besucherstühle

Goal-Air visitors' chairs

Goal-Air sièges de visiteur

Goal-Air bezoekerstoelen

Goal-Air sillas para de visitas

Goal-Air seduta per visitatore

580G



585G



Interstuhl

Büromöbel GmbH & Co. KG

Brühlstraße 21

D-72469 Meßstetten-Tieringen

Phone +49 -7436-871-0

Fax +49 -7436-871-110

info@interstuhl.de

www.interstuhl.de